

J. GRETTY & J. MILLS.
Machine for Making Framed Wood Work.
No. 222,693. Patented Dec. 16, 1879.

FIG. 1.

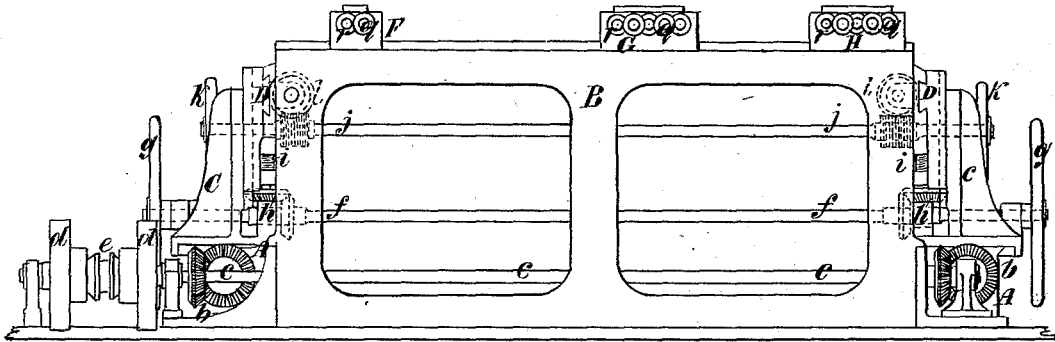

FIG. 3

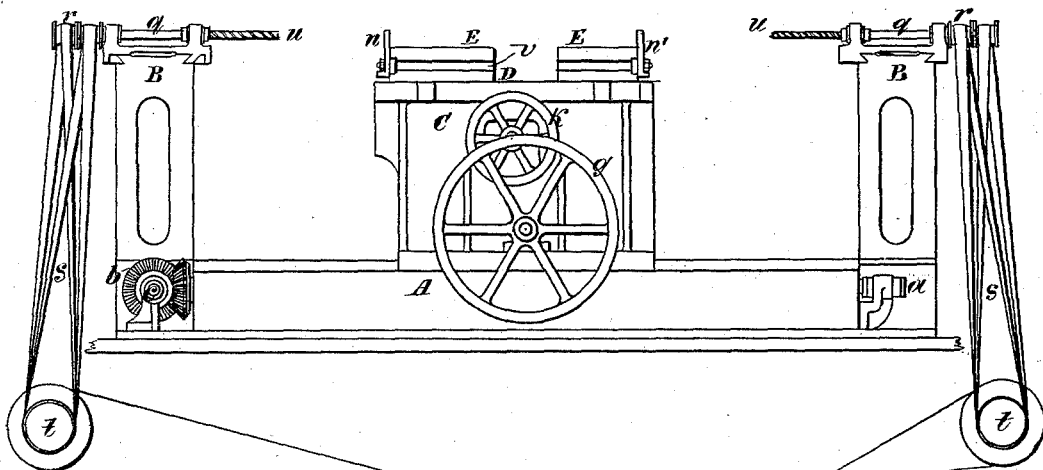

FIG. 4



FIG. 5



Witnesses
Alexander Patterson Jr
Harry Smith

Inventors
Jonathan Gresty
and
John Mills
by their Attorneys
Howden and Co

J. GRETTY & J. MILLS.
Machine for Making Framed Wood Work.
No. 222,693. Patented Dec. 16, 1879.

FIG. 2.

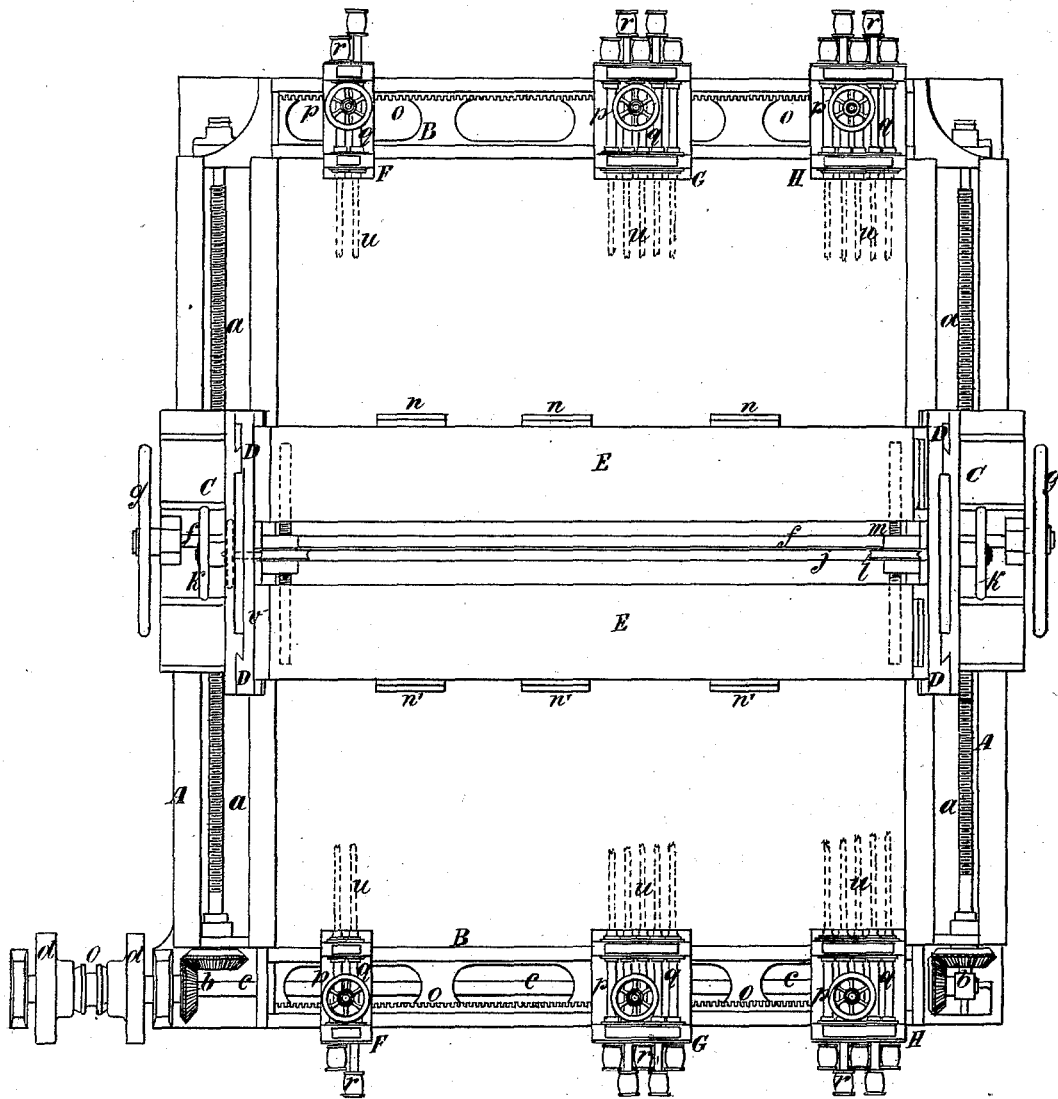

Witnesses
 Alexander Patterson Jr.
 Harry Smith

Inventors
 Jonathan Gresty
 and
 John Mills
 by their Attorneys
 Howson and Co

J. GRETTY & J. MILLS.
Machine for Making Framed Wood Work.
No. 222,693. Patented Dec. 16, 1879.

FIG. 6

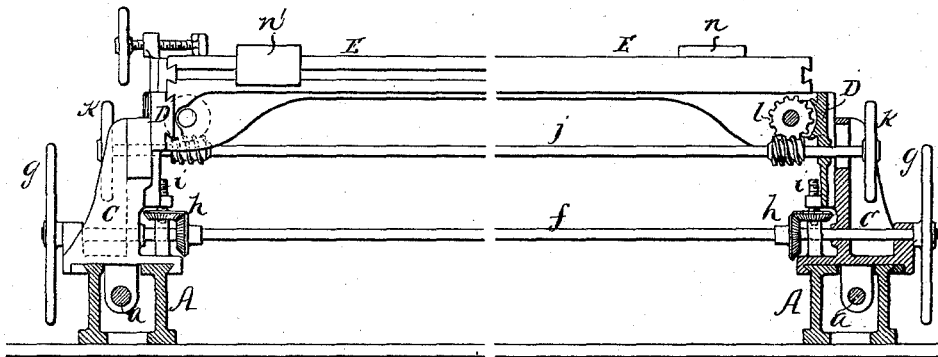

WITNESSES

J. M. Deemer
Henry Lawson Jr.

INVENTORS

Jonathan Gretty
and John Mills
by their Attorneys
Howson and Son

UNITED STATES PATENT OFFICE

JONATHAN GREY AND JOHN MILLS, OF SALFORD, COUNTY OF LANCASTER,
GREAT BRITAIN.

IMPROVEMENT IN MACHINES FOR MAKING FRAMED WOOD-WORK.

Specification forming part of Letters Patent No. **222,693**, dated December 16, 1879; application filed
June 9, 1879.

To all whom it may concern:

Be it known that we, JONATHAN GREY and JOHN MILLS, of Salford, in the county of Lancaster, Kingdom of Great Britain, have invented new and useful Improvements in Machines for Making Framed Wood-Work, of which the following is a specification.

Our invention relates to the boring and connecting together of the parts of doors, wainscots, window-frames, and other framed wood-work. The piece of wood-work—say, for example, a door—is formed of parts which are tongued and grooved, as is usual, but are not mortised nor formed with the usual tenons. The said parts are put together and are placed upon a clamping-table which can be raised and lowered, and also traversed to and fro. The said table, by traveling in one direction, subjects the work to the action of a set of borers, and by traveling in the opposite direction subjects the work to the action of a second set of borers. The table being lowered, the traversing of the table is employed to force home dowels, which are inserted into the holes, which are supplied with glue.

In the accompanying drawings, Figure 1, Sheet 1, is a side elevation; Fig. 2, Sheet 2, a plan; Fig. 3, Sheet 1, a front elevation of our improved machine; Figs. 4 and 5, views showing the work done by the machine; and Fig. 6, Sheet 3, the transverse section of a machine which is particularly adapted to be employed in the formation of doors.

In the said figures, A A are two bed-castings, which are connected with end head-stocks, B B, the whole forming a rectangular foundation-framing. The upper parts of the beds A are formed with V-slides, and are planed to receive standards or head-pieces C C, which are fitted to slide to and fro upon the said beds. Each head-piece C is formed with dovetailed guides to receive a sliding plate, which is adapted to slide up and down vertically upon the said head-piece.

Upon the outer face of each plate D is formed a horizontal dovetailed guide, and the ends of a table, E, which is formed in two parts, are planed, and fitted to slide on the said horizontal guide.

The standards and work-table constitute a traveling carriage for the material to be operated on. In the example all these sliding parts are mounted upon their guides in a similar manner to the sliding parts of a lathe slide-rest; but this particular construction may not be necessary in all cases.

In suitable bearings in or upon each bed A a screw, *a*, is fitted to revolve, and each of the two screws is connected by bevel-gearings *b* with a cross-shaft, *c*. Each screw is adapted to a threaded nut fixed to the corresponding standard C, the effect being that, when the cross-shaft *c* is caused to revolve the two screws revolve in unison, and the two standards are caused to slide in unison upon their beds in the same direction and to the same extent, so that all parts of the work-table will move together.

Upon one end of the shaft *c* two pulleys, *d*, are mounted, and arrangements are provided for driving the two pulleys in contrary directions—as, for example, by means of a cross and open strap.

The hubs of the two pulleys are formed as conical friction-clutches, and a sliding clutch, *e*, is mounted between the two pulleys, and is arranged to be slid into frictional gear with one or the other of the pulleys by means of a hand-lever, or by a suitable arrangement of parts, in order that the shaft *c* may be caused to revolve in one direction or the other, or its movement be quickly arrested, when required, either automatically or by hand.

A shaft, *f*, extends from one to the other of the head-pieces or standards C, and is provided with two hand-wheels, *g*, in order that it can be rotated from either side of the machine. The said shaft is connected by two sets of bevel-gearings, *h h*, with two screws, *i i*, each of which is mounted in a footstep fixed to the standard C, and works in a nut fixed to or formed in the plate D, Fig. 6. The effect of this arrangement is, that when one of the hand-wheels *g* is rotated the two slides D are caused to slide up or down upon their standards, according to the direction in which the hand-wheel is turned, the movements of the two slides being simultaneous in the same di-

rection, and to the same extent, so that the horizontal position of the table E is maintained.

A second shaft, *j*, extends from one to the other of the two cross-slides D, being mounted in bearings attached to or formed therein, and is provided at each end with a hand-wheel, *k*, as in the case of the shaft *f*.

Upon the shaft *j* are mounted or formed two worms, which gear with worm-wheels *ll*, fixed upon or secured to the central parts of screw-rods *m m*. Each of the said screw-rods is formed on one side of the central wheel with a right-hand thread, and on the other side with a left-hand thread.

The right-hand portions of the screws work in nuts fixed to one part of the table E, and the left-hand portion in nuts fixed to the other part of the said table, so that when the shaft *j* is rotated the said screws are caused to revolve simultaneously, whereby the two portions of the table are caused to approach each other or to recede from each other, according to the direction in which the hand-wheel *k* is turned, the screws maintaining the parallelism of the two portions of the table in their various positions.

Dovetailed grooves are formed along the outer edges of each part of the table E, Fig. 3, and the heads of V-headed bolts are retained in the said grooves, the said bolts serving to secure clamping-plates *n n'* to the table. The said plates can be slid to and fro in the grooves along the edges of the table when the bolts are slackened, whereby the positions of the plates can be adjusted.

The upper surfaces of the head-stocks B are planed to receive carriages F, G, and H, which are fitted to slide upon the head-stocks, the latter being formed with dovetailed guides, as in the case of a slide-lathe bed, as seen in Fig. 3.

A rack, *o*, is fixed to each head-stock, and pinions fixed to short shafts, which are mounted in the carriages, and are provided with hand-wheels *p*, gearing with the said rack. Each carriage can be slid along the head-stock by turning the wheel *p*, the planed slides upon the head-stock maintaining the parallelism of the carriages.

In the example three carriages are mounted upon each head-stock; but this number may be varied as required. In each carriage bearings are formed to receive spindles *q q*, there being in the example two spindles in the carriage F, and five spindles in the carriages G and H; but the number of spindles may be varied to suit the requirements of any case.

Each spindle is formed or provided with a strap-pulley, *r*, and arrangements are made to impart a rapid revolving motion to all the spindles.

In Fig. 3 the pulleys *r* are connected by straps *s* with drums or pulleys fixed upon counter-shafts *t t*, which are fitted to revolve

below the floor-line, and receive motion from the main shaft J.

The spindles may be caused to revolve by means of any suitable arrangement of straps, cords, gearing, or equivalent appliances.

Each spindle is provided with a borer, *u*, Figs. 2 and 3, any suitable boring-bit being used.

The operation of the machine may be described as follows: The machine is represented as adjusted for employment in the putting together of doors formed with a head rail, a middle rail, and a bottom rail. The parts of such a door are grooved and tongued, as usual, but are not formed with the usual tenons on the rails, nor are the stiles mortised. The parts are put together and placed upon the table E. If not previously adjusted, the spindle-carriages are so adjusted that the borers of the carriage F shall be in line with the head rail, and the borers in G and H in line with the middle and bottom rails. One of the hand-wheels *k* is turned in the direction which will cause the parts of the table E to approach each other, whereby the clamping-plates *n n'* are caused to press forcibly against the stiles, and the tongues on the rails are thereby forcibly pressed home into the stiles.

In practice, we also employ other clamps acting in a direction at right angles to the lines of action of the table E. For this purpose we secure brackets to the plates D, or to one of them, and in each bracket, or on or to the bracket, is formed or fixed a nut, in which works a screw, by means of which pressure is brought to bear upon the center of the head or bottom rail, or upon both, so as to close in the joints of the rails with the center stiles; or we form the said nut in a part which is fitted to slide in V-slots formed in the ends of the table E, Fig. 6. The parts being clamped together, the shaft C is started, whereby the carriage carrying the work is caused to travel toward one of the head-stocks. The movement of the carriage is continued until the twelve borers have penetrated through one of the stiles the required depth into the rails, when the direction of traverse of the table is reversed, and the table is thereby carried toward the other head-stock, and the other stile and the other ends of the rails are bored. During the last-mentioned traverse of the table, glue is applied to the interiors of the bored holes, and dowels or wood pegs dipped in glue are inserted and lightly driven into the said holes, as in Fig. 4.

The boring of the second set of holes being completed, the table is again reversed, and dowels are inserted into the second set of holes.

The table is lowered by turning one of the wheels *k* to such an extent that, when the table is permitted again to traverse to and fro, the work passes below the borers and the outer ends of the dowels come into contact with the

front edges of the borer-carriages, whereby all the dowels in a side are forced home simultaneously. The connection of the parts being now completed, the door is released and removed.

It is preferred that the pins or dowels shall not pass entirely through the stiles, the rails may be fixed in position upon the table at gaged distances apart, and holes be bored in the rails, and the stiles may be bored with the same borers, the holes in the stiles being bored from the inside or grooved edge nearly through the stiles. The stiles and rails may then be put together with dowels, as in Fig. 5.

We claim as our invention—

1. The combination of boring mechanism, with sliding head pieces or standards C C, a vertically-sliding plate, D, adapted to each standard, and a table, E, adapted to horizontal guides on the plate D, and made in two parts adapted to slide in opposite directions, with clamping devices, all substantially as described.

2. The combination of the work-table, mounted

on sliding head pieces, with the two parallel head-stocks, each provided with a series of carriages, F G H, carrying boring-tools and adjustable laterally on the head-stock, substantially as described.

3. The combination of boring-tools, mounted in carriages on head-stocks, and the work-table E, mounted on sliding head-pieces or standards, with feed-screws *a a*, for said head-pieces, and shaft *c*, provided with driving mechanism, and geared to both screws, *a a*, substantially as described.

4. The head-stock B, provided with a rack, *o*, in combination with carriages F G H, adapted to slide on said head-stock, and provided with pinions gearing with said rack, all substantially as described.

JONATHAN GRETTY. [L. S.]
JOHN MILLS. [L. S.]

Witnesses:

HUGH GRANT,
THOS. PRESCOTT.